

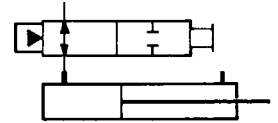

HYDRAULIC CYLINDERS

with Hydraulic Depth Control

TIE ROD CYLINDERS
DC SERIES
Specification Sheet

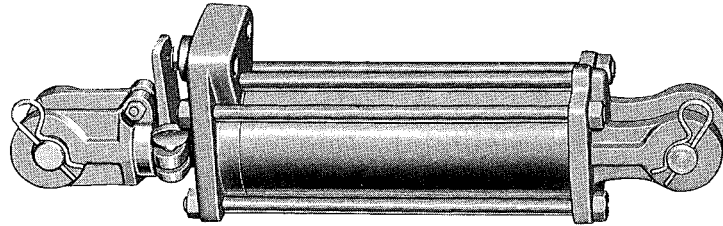

The CROSS series DC tie rod type hydraulic cylinders feature hydraulic depth control with an infinitely variable adjustment from zero to maximum stroke. Long life and reliable operation are provided by the many design features plus high quality workmanship and materials.

GENERAL SPECIFICATIONS

Rated working pressure (Max. relief valve setting at full flow) 2500 psi (172 bar)
Maximum shock and surge pressure 4000 psi (276 bar)

Bore diameters	3.00	3.50	4.00	5.00	in.
	76	89	102	127	mm

MATERIAL SPECIFICATIONS

Cylinder barrelsST 52.3 steel alloy
PistonsHigh strength aluminum or gray iron
RodsIntroduction hardened C1045 steel alloy
Base castings and rod clevisesDuctile iron
Cylinder headsHigh tensile strength gray iron
Seals70 durometer Buna N o-rings with polyurethane back-up rings
.Double lipped polyurethane u-cup rod seal

STANDARD FEATURES

- Infinitely adjustable stroke from zero to maximum stroke
- Heavy duty rod clevis with hardened steel bushings
- Hardened steel pins
- Cylinder barrels are skived burnished precision finished to provide long seal life
- Rods are hardened, chrome plated and polished for long wear life and for protection from external damage and corrosion
- Rod wipers clean dirt and foreign matter from rod to insure long seal life
- High tensile strength tie rods with rolled threads for durability
- NPTF dryseal pipe thread ports
- Standard ASAE 8" and 16" strokes

OPTIONAL FEATURES AVAILABLE

- SAE straight thread o-ring ports (top ported)
- 1.25 diameter hardened pins (standard on 16" stroke ASAE and 5.00 bore diameter cylinders)



DIMENSIONAL DATA in inches and (millimeters)

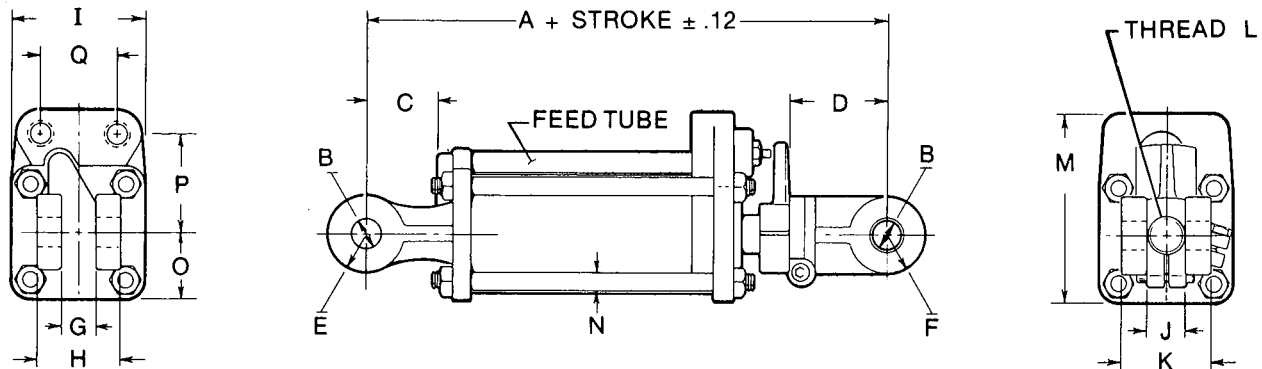

ALL DIMENSIONS ARE NOMINAL

BORE DIA	A	B	C	D	E	F	G	H	I	J	K	L	M	N	O	P	Q
3.0" (76)	12.25 (305)	1.015 (25.8)	2.38 (60.4)	3.25 (82.5)	1.25 (31.8)	1.25 (31.8)	1.12 (28.4)	2.75 (69.8)	3.75 (95.2)	1.25 (31.8)	2.75 (69.8)	1 1/4 -12	5.88 (149.4)	.50 (12.7)	1.88 (47.8)	3.25 (82.6)	2.50 (63.5)
3.5" (89)	12.25 (305)	1.015 (25.8)	2.38 (60.4)	3.25 (82.5)	1.25 (31.8)	1.25 (31.8)	1.12 (28.4)	2.75 (69.8)	4.25 (108)	1.25 (31.8)	2.75 (69.8)	1 1/4 -12	6.12 (155.4)	.56 (14.2)	2.12 (53.8)	3.25 (82.6)	2.50 (63.5)
4.0" (102)	12.25 (305)	1.015 (25.8)	2.38 (60.4)	3.25 (82.5)	1.25 (31.8)	1.25 (31.8)	1.12 (28.4)	2.75 (69.8)	5.00 (127)	1.25 (31.8)	2.75 (69.8)	1 1/4 -12	6.69 (169.9)	.62 (15.7)	2.50 (63.5)	3.44 (87.4)	2.50 (63.5)
5.0" (127)	12.25 (305)	1.265 (32.1)	2.28 (57.9)	3.25 (82.5)	1.41 (35.8)	1.25 (31.8)	1.34 (34.0)	3.50 (88.9)	6.00 (152)	1.25 (31.8)	2.75 (69.8)	1 1/2 -12	7.26 (184.4)	.75 (19.0)	3.0 (76.2)	3.54 (89.9)	2.50 (63.5)

CYLINDER PORTS and RODS

BORE DIA.	PORT SIZE & TYPE		8 INCH STROKE (20.25" RETRACTED)			16 INCH STROKE (31.5" RETRACTED)	
	STANDARD	OPTIONAL	STD. ROD	OPT. ROD.		STD. ROD	OPT. ROD.
3.0" (76)	1/2" NPTF	3/4-16	1.25 (31.8)	1.50 (38.1)		1.25 (31.8)	1.50 (38.1)
3.5" (89)			1.25 (31.8)	1.50 (38.1)	1.75 (44.4)	1.50 (38.1)	NONE
4" (102)	1/2" NPTF	3/4-16	1.25 (31.8)	1.50 (38.1)	2.00 (50.8)	1.75 * (44.4)	2.00 (50.8)
5" (127)	1/2" NPTF	3/4-16	2.00 (50.8)	1.75 (44.4)		2.00 (50.8)	NONE

* Limited to 2300 psi maximum working pressure.

ORDERING INFORMATION

SERIES	BORE DIA. (in. x 100)	STROKES (in. x 100)	ROD DIA. (in. x 100)	PORT SIZE & TYPE
DC	300	800 1600	125	D 3/4 - 16 SAE
	350		150	
	400		175	R
	500		200	1/2 NPTF



CROSS MANUFACTURING, INC.

100 Factory Street
Lewis, Kansas 67552

Phone 620/324-5525; FAX 620/324-5737; e-mail: info@crossmfg.com