

AD1 series DIRECTIONAL CONTROL VALVE

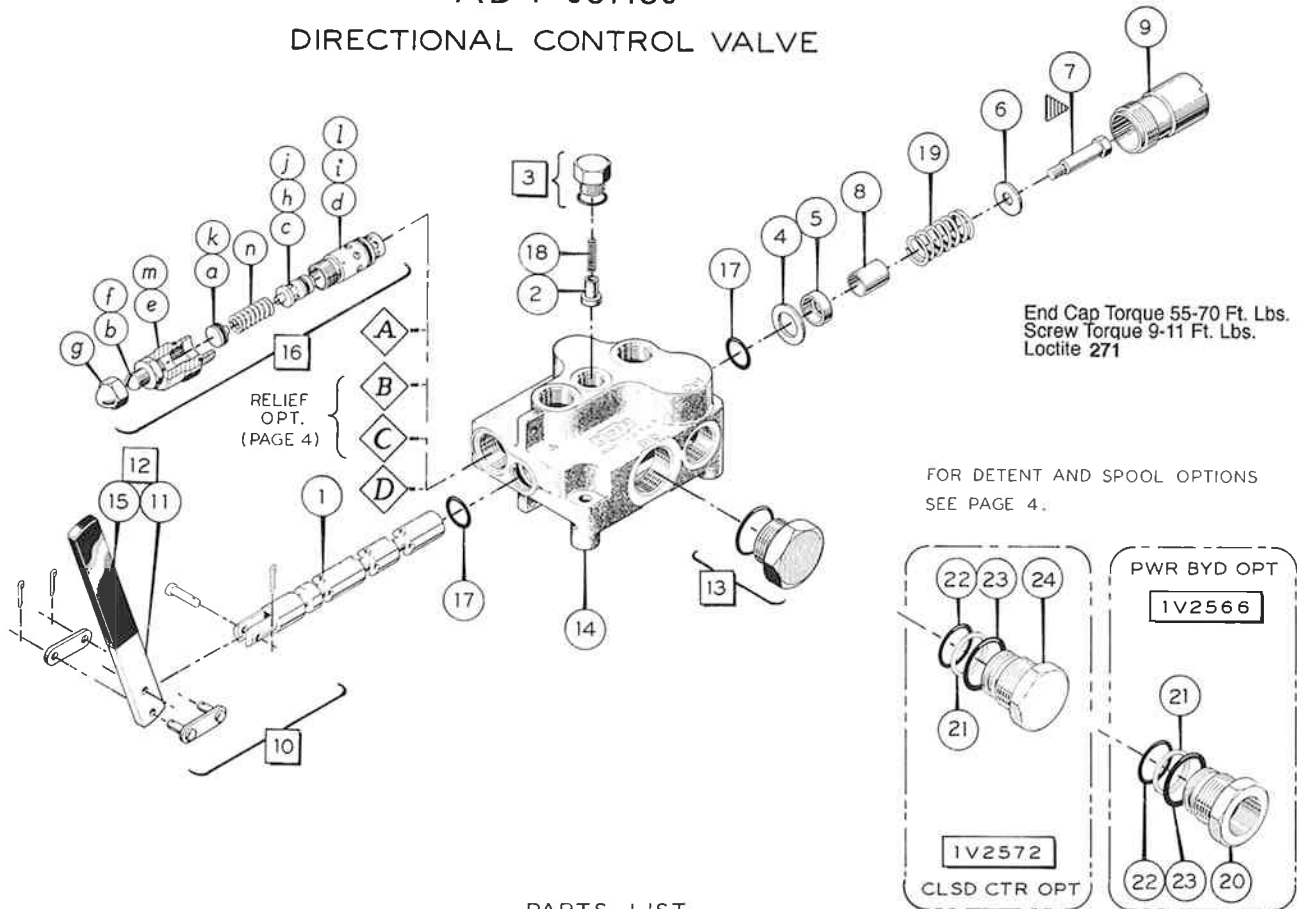

PARTS LIST

QTY	PART NO.	DESCRIPTION	QTY
1	1V2534 *	SPOOL, 4-WAY FLOAT	1
2	1V2550	POPPET, LOAD CHECK	1
3	1V2552	PLUG ASSY, LOAD CHECK	1
4	1V2553-60	SEAL RETAINER	1
5	1V2554	SPOOL COLLAR	1
6	1V2555	WASHER	1
7	1V2573	SPOOL END SCREW	1
8	1V2574	STOP COLLAR, SPOOL	1
9	1V2575	END CAP, 4-WAY	1
10	1V2597	PIN KIT	1
11	1V2589	HANDLE	1
12	1V2592	HANDLE & COVER KIT	1
13	1V2602	CONVERSION PLUG ASSY	1
14	1V3100 *	BODY	1
15	1A9116	HANDLE COVER	1
16	1R0155	RELIEF VALVE CARTRIDGE INCL:	1
a	1R0013	PISTON	1
b	1R0015	ADJUSTMENT SCREW	1
c	1R0020	POPPET	1
d	1R0130	BODY, LOWER	1
e	1R0145	BODY, UPPER	1
f	1A0569	NUT	1
g	1A0570	ACORN NUT	1
h	2A0007-11	BACK-UP	1
i	2A0007-15	BACK-UP	1

QTY	PART NO.	DESCRIPTION	QTY
j	2A0283-7011	O-RING	1
k	2A0283-7012	O-RING	1
l	2A0283-7015	O-RING	1
m	2A0283-9910	O-RING	1
n	2A9048-7	SPRING, 1500-3000 PSI	1
17	2A0283-7114	O-RING	2
18	2A9021-1	SPRING, LOAD CHECK	1
19	2A9074-1	CENTERING SPRING	1
-	2A0358-12	SHIPPING PLUG	2
-	2A0358-14	SHIPPING PLUG	2
-	2V0051	SEAL KIT	0

POWER BEYOND OPTION

1V2566 SLEEVE ASSEMBLY INCLUDES:

20	1V2565	SLEEVE	1
21	2A0007-016	BACK-UP	1
22	2A0283-7016	O-RING	1
23	2A0283-9914	O-RING	1

CLOSED CENTER OPTION

1V2572 PLUG ASSEMBLY INCLUDES:

21	2A0007-016	BACK-UP	1
22	2A0283-7016	O-RING	1
23	2A0283-9914	O-RING	1
24	1V2571	PLUG	1

* THE SELECT-FIT HONING PROCESS AT FACTORY, WHICH FITS A SPOOL TO AN INDIVIDUAL VALVE BODY, ELIMINATES THE POSSIBILITY OF ORDERING THE VALVE BODY OR SPOOL AS SEPARATE ITEMS.

AD 2 series DIRECTIONAL CONTROL VALVE

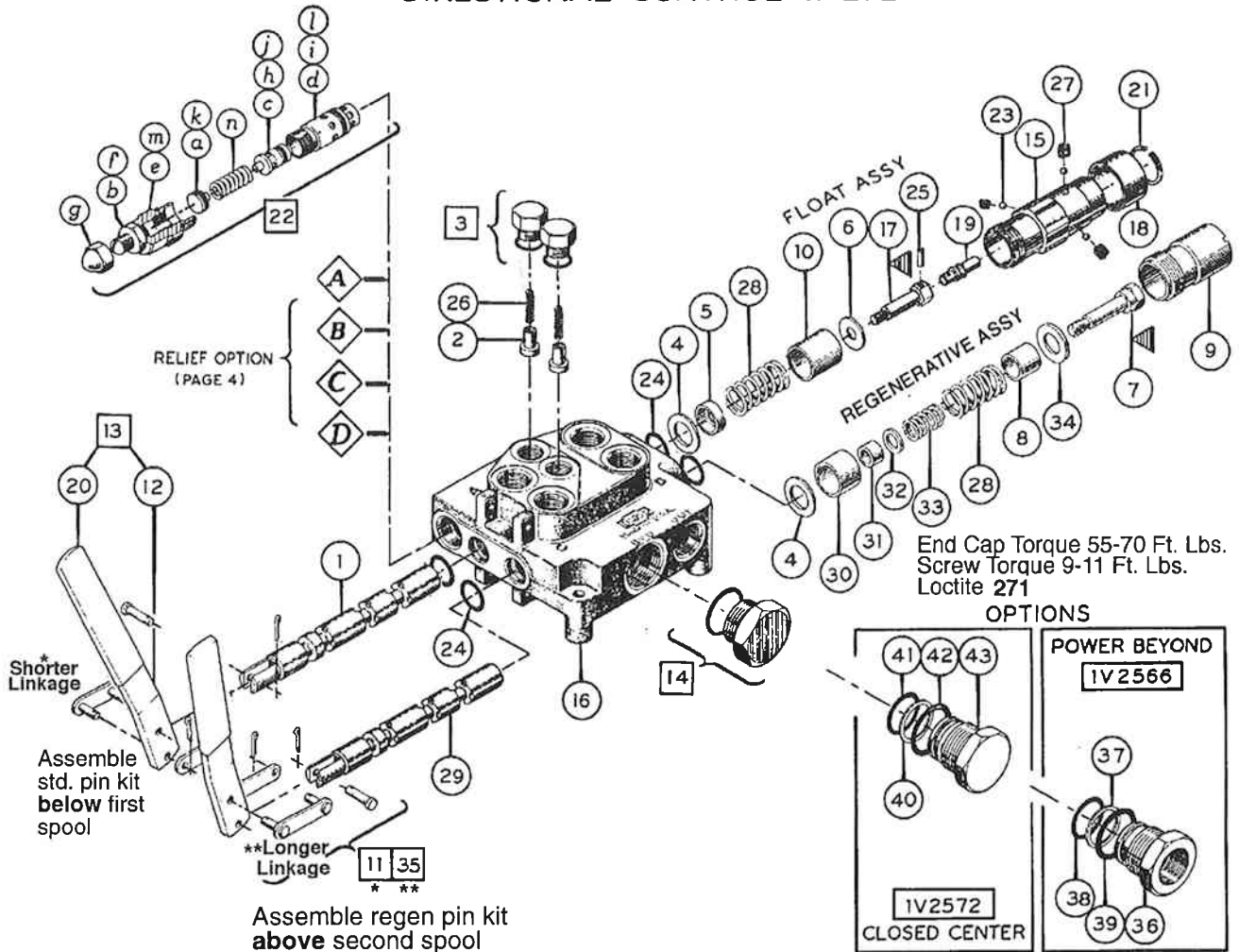

PARTS LIST

QTY.	PART NO.	DESCRIPTION	QTY.	PART NO.	DESCRIPTION	QTY.
1	1V2534	SPOOL, 4-WAY FLOAT	1	j	2A0283-7011	O-RING
2	1V2550	POPPET, LOAD CHECK	2	k	2A0283-7012	O-RING
3	1V2552	PLUG ASS'Y,LOAD CHECK	2	l	2A0283-7015	O-RING
4	1V2553-60	SEAL RETAINER	2	m	2A0283-9910	O-RING
5	1V2554	SPOOL COLLAR	1	n	2A9048-7	SPRING, 1500-3000 PSI
6	1V2555	WASHER	1	23	2A0017-6	BALL
7	1V2567	END SCREW, REGEN	1	24	2A0283-7114	O-RING
8	1V2577	SPOOL STOP, REGEN	1	25	2A0493-407	ROLL PIN
9	1V2564	END CAP, REGEN	1	26	2A9021-1	SPRING, LOAD CHECK
10	1V2581	SPOOL STOP COLLAR, FLOAT	1	27	2A9024-5	DETENT SPRING
11	1V2597	PIN KIT	1	28	2A9074-1	CENTERING SPRING
12	1V2599	BENT HANDLE	2	29	1V2545	SPOOL, REGEN
13	1V2600	HANDLE & COVER KIT	2	30	1V2570	SPOOL COLLAR, REGEN
14	1V2602	CONVERSION PLUG ASS'Y.	1	31	1V2568	SPACER, REGEN
15	1V2612	END CAP, DETENT	1	32	1V2576	WASHER, REGEN
16	1V2615*	BODY	1	33	2A9042-5	SPRING, AD DETENT
17	1V2670	END SCREW, DETENT	1	34	1V2569	WASHER, REGEN SPRING
18	1V2671	SLEEVE, DETENT	1	35	1V2548	PIN KIT, REGEN
19	1V2672	DETENT STEM, FLOAT	1	-	2A0353-14	SHIPPING PLUG
20	1A9116	HANDLE COVER	2	-	2A0353-14	SHIPPING PLUG
21	1A9045	RETAINING RING	1		2V0050	SEAL KIT
22	1R0155	RELIEF VALVE CARTRIDGE	1	1V2565 P/B SLEEVE ASSEMBLY INCLUDES:		
a	1R0013	PISTON	1	36	1V2565	SLEEVE
b	1R0015	ADJUSTMENT SCREW	1	37	2A0007-016	BACK-UP
c	1R0020	POPPET	1	38	2A0283-7016	O-RING
d	1R0130	BODY, LOWER	1	39	2A0283-9914	O-RING
e	1R0145	BODY, UPPER	1	1V2572 CC PLUG ASSEMBLY INCLUDES:		
f	1A0569	NUT	1	40	2A0007-016	BACK-UP
g	1A0570	ACORN NUT	1	41	2A0283-7016	O-RING
h	2A0007-011	BACK-UP	1	42	2A0283-9914	O-RING
i	2A0007-015	BACK-UP	1	43	1V2571	PLUG

OPTIONS FOR AD1 AND AD2 SERIES

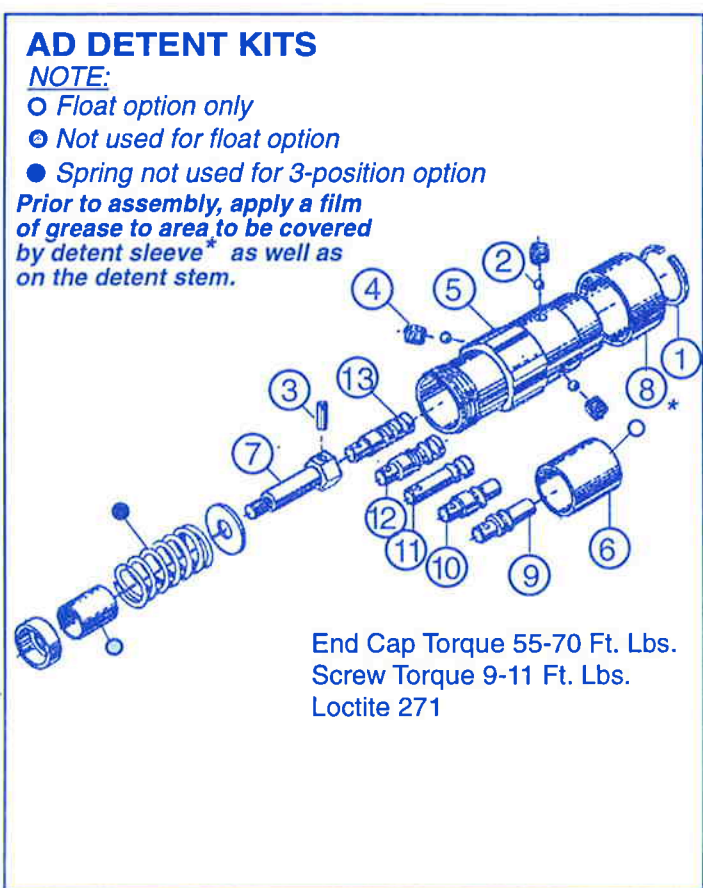
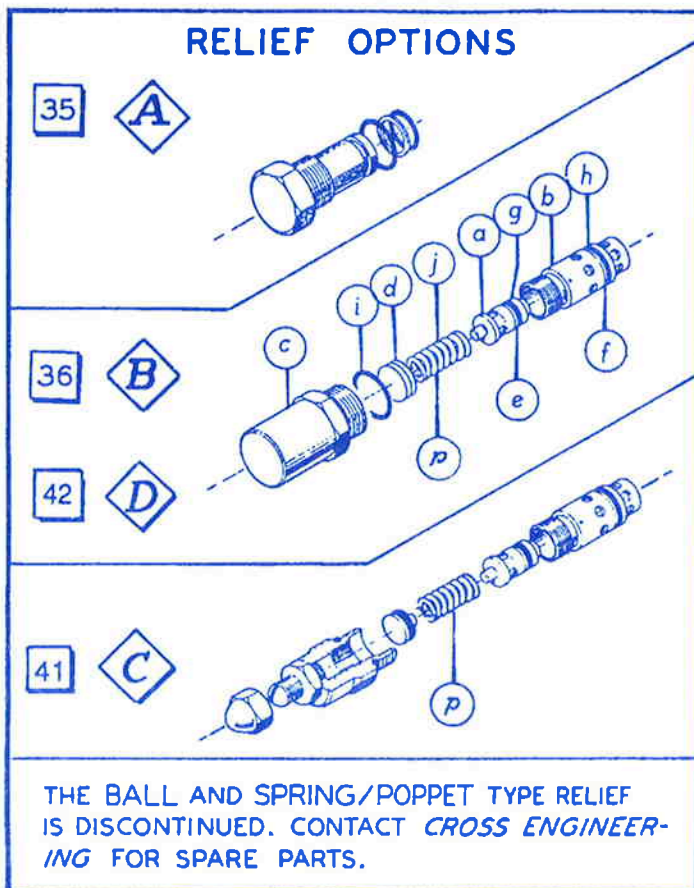

○	PART NO.	DESCRIPTION	QTY.
RELIEF OPTIONS			
35	A 1R0035	RELIEF PLUG ASSEMBLY	1
<i>NO RELIEF (USE C.C. OPT.)</i>			
36	B 1R0165	NON-ADJ. RELIEF VALVE INCL	
a	1R0020	POPPET	1
b	1R0130	BODY, LOWER	1
c	1R0160	BODY, UPPER	1
d	1A0687	SHIM	AS NEEDED
e	2A0007-011	BACKUP	1
f	2A0007-015	BACKUP	1
g	2A0283-7011	O-RING	1
h	2A0283-7015	O-RING	1
i	2A0283-9910	O-RING	1
j	2A9048-7	SPRING, 1500 - 3000 psi	1
41	C 1R0150	ADJ. DIFF. RELIEF	1
IDENTICAL TO 16 ON PAGE 2, EXCEPT FOR :			
p	2A9048-6	SPRING (500-1500 PSI)	1
42	D 1R0164	NON ADJ. RELIEF CART.	1
IDENTICAL TO 36 B EXCEPT FOR :			
p	2A9048-6	SPRING (500-1500PSI)	1

○	PART NO.	DESCRIPTION	QTY.
1	1A9045	RETAINING RING	1
2	2A0017-6	BALL, DETENT	3
3	2A0493-407	ROLL PIN	1
4	2A9024-5	SPRING, DETENT	3
5	1V2612	END CAP, DETENT	1
6	1V2581	SPOOL STOP, FLOAT	1
7	1V2670	END SCREW, DETENT	1
8	1V2671	SLEEVE, DETENT	1
9	1V2672	DETENT STEM, FLOAT	1
10	1V2673	DETENT STEM, IN	1
11	1V2674	DETENT STEM, OUT	1
12	1V2675	DETENT STEM, 2 POS.	1
13	1V2676	DETENT STEM, 3-POS.	1
<i>Note: Order by Kit Number</i>			
	1V2680	DETENT KIT, 1 POS. OUT	1
	1V2681	DETENT KIT, 1 POS. IN	1
	1V2682	DETENT KIT, 2 POS.	1
	1V2683	DETENT KIT, 3 POS.	1
	1V2684	DETENT KIT, FLOAT	1

CROSS MANUFACTURING INC. RESERVES THE RIGHT TO DISCONTINUE PRODUCTS AND/OR CHANGE DESIGN, SPECIFICATIONS OR PRICES AT ANY TIME WITHOUT INCURRING ANY OBLIGATION.

SEE FM VAD SPECIFICATION SHEET FOR DIMENSIONAL DATA AND ORDERING INFORMATION.