

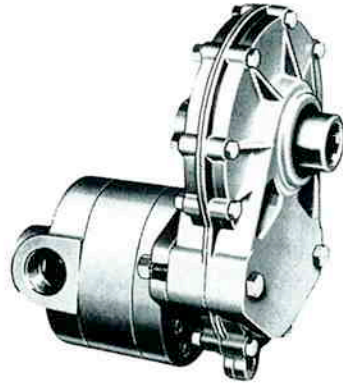

# HYDRAULIC PUMPS

## GEAR PUMPS 50T SERIES Specification Sheet

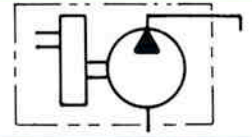

The CROSS Series 50T hydraulic pumps are designed to be driven by a 540 or 1000 rpm PTO and provide a 3:1 speed increase. The thru-type internal spline permits the use of a stub shaft PTO driven accessory while simultaneously driving the pump.

### GENERAL SPECIFICATIONS

Effective displacement sizes. . . .

4.6	5.6	7.0	8.2	9.9	11.4	15.6	cu. in/rev.
75	96	114	135	162	187	256	cc/rev.

Rated working pressure (max. relief valve setting at full flow) 3000 psi (207 bar)  
*except as noted*

540 rpm option: 50T038 - 2700 psi(186 bar); 50T052 - 2000 psi (138 bar)

1000 rpm option: 50T023 - 2650 psi (182 bar); 50T027 - 2300 psi (158 bar); 50T033 - 1850 psi (127 bar)

Maximum shock and surge pressure. . . . . 3500 psi (242 Bar)

Maximum input speed (continuous). . . . . Up to 1000 rpm

Maximum flow rate (delivery) at 540 rpm. . . . . 32.8 gpm (124 l/m)

Maximum flow rate (delivery) at 1000 rpm. . . . . 38.6 gpm(146 l/m)

Maximum input horsepower . . . . . 42 hp(31 Kw)

Mounting. . . . . PTO, torque arm

Weight. . . . . Approx. 38 lbs. (17 Kg)

### MATERIAL SPECIFICATIONS:

Pump body and end covers, speed increaser housing. . . . die cast aluminum alloy

Pump gears and shafts . . . . . hardened steel

Increaser gears and shafts. . . . . hardened steel

Seals . . . . . Buna N

### STANDARD FEATURES:

- Left hand rotation - right hand pump required (gear box reverses direction)
- Side port location
- Hole for 3/8" dia. bolt for torque arm attachment
- SAE #20 (1 1/4") o-ring (1 5/8"-12) or SAE #24(1 1/2") o-ring (1 7/8-12) inlet port
- SAE #16 (1") o-ring outlet port (1 5/16-12)

### OPTIONAL FEATURES AVAILABLE: • Rear port location

**Notes:** PTO torque arm must be attached to keep unit from rotating. The speed increaser case is lubricated through the pump. The 50T unit uses a special pump configuration. Refer to CROSS pump and motor technical service sheet for special instructions, start-up procedures, filter and oil recommendations, etc.



**DIMENSIONAL DATA**

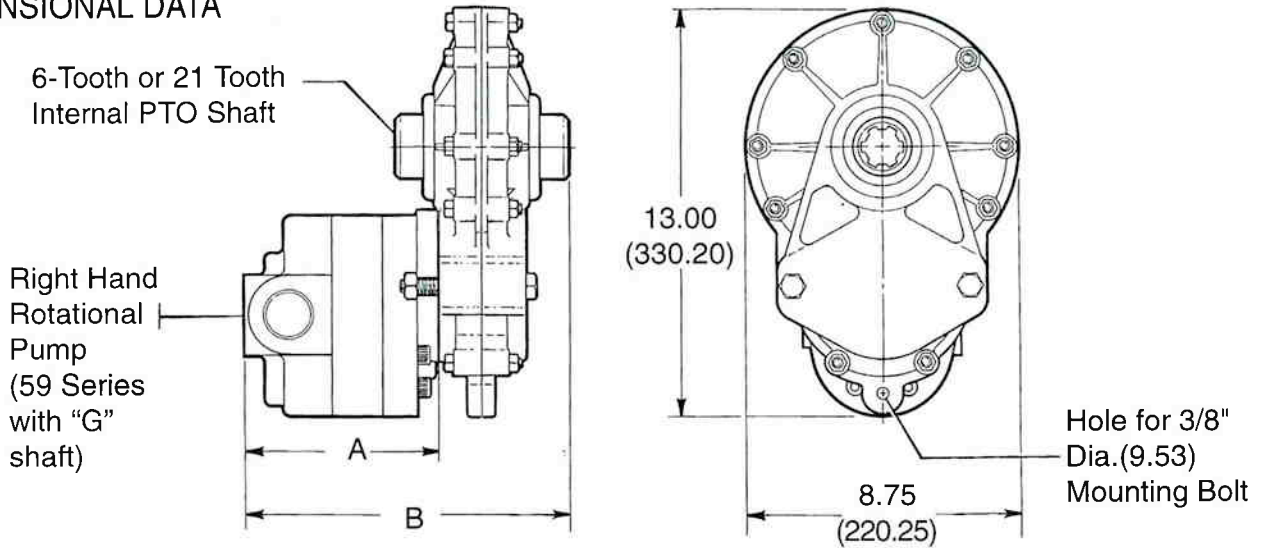

Model No.	50T015	50T019	50T023	50T027	50T033	50T038	50T052	
Dimension "A"	5.60 (142.2)	5.80 (147.3)	5.96 (151.4)	6.15 (156.2)	6.40 (162.6)	6.62 (168.1)	7.21 (183.1)	in. mm
Dimension "B"	9.72 (247.0)	9.92 (252.1)	10.08 (256.2)	10.28 (261.0)	10.52 (267.3)	10.74 (272.9)	11.34 (287.9)	in. mm
Flow at 540 rpm	9.6 (36)	12.3 (47)	14.6 (55)	17.3 (65)	20.8 (79)	24.0 (91)	32.8 (124)	gpm l/m
Flow at 1000 rpm	17.8 (67)	22.8 (86)	27.1 (103)	32.0 (121)	38.6 (146)			gpm l/m

**ORDERING DATA**

Series	Type	Special Options	Size cu.in/R x 10	Rotation	Mounting	Shaft Size & Type	Ports Location & Size			
							In	Out		
50	T	O	15 19 23 27 33 38 52	L Left Hand	T PTO	A* 6 tooth PTO Spline  S 21 tooth PTO Spline	SA	1 <sup>7</sup> / <sub>8</sub>	1 <sup>5</sup> / <sub>16</sub>	Side Ports
							SB*	1 <sup>5</sup> / <sub>8</sub>	1 <sup>5</sup> / <sub>16</sub>	
							RD	1 <sup>7</sup> / <sub>8</sub>	1 <sup>5</sup> / <sub>16</sub>	Rear Ports
							RE	1 <sup>5</sup> / <sub>8</sub>	1 <sup>5</sup> / <sub>16</sub>	

For Typical Performance Refer to 50 Series Literature (Form P501) \* Standard for Full Line Distributor program



**CROSS MANUFACTURING, INC.**  
100 Factory Street  
Lewis, Kansas 67552  
Phone 620/324-5525; FAX 620/324-5737; e-mail: info@crossmfg.com